

Comparison of heterogeneous and homogeneous radioactivity flow detectors for simultaneous profiling and LC-MS/MS characterization of metabolites

Laura A. Egnash, Ragu Ramanathan *

*Division of Drug Metabolism, Department of Pharmacokinetics, Dynamics and Metabolism,
Pfizer Global Research and Development-Ann Arbor, 2800 Plymouth Road, Ann Arbor, MI 48105, USA*

Received 1 March 2001; received in revised form 16 July 2001; accepted 26 July 2001

Abstract

Methods for simultaneous liquid chromatography-radioactivity monitor (LC-RAM) metabolite profiling and LC-tandem mass spectrometry (MS/MS) characterization of metabolites are described. Profiling and characterization of metabolites from three drug candidates from different therapeutic areas were compared using in-line heterogeneous LC-RAM-MS/MS and homogeneous LC-RAM-MS/MS methods. Although comparison shows that simultaneous metabolite profiling and characterization can be achieved using either heterogeneous or homogeneous-LC-RAM-MS/MS systems, a homogeneous system has the advantage in the following aspects, (1) sensitivity; (2) ease of method transfer; (3) less peak broadening problems due to the drug or metabolites adhering to the RAM cell; (4) accuracy in quantitation of the metabolites; and (5) the ability to load larger volumes of unprocessed biological fluids. Furthermore, the study shows that some of the possible metabolites that do not ionize well with electrospray ionization (ESI) and eluted detection by heterogeneous-LC-RAM detection could be very easily detected and characterized using a homogeneous-LC-RAM-MS/MS system. © 2002 Elsevier Science B.V. All rights reserved.

Keywords: Liquid chromatography-radioactivity monitor (LC-RAM); Electrospray ionization (ESI); Metabolites

1. Introduction

The process of drug metabolism generally involves conversion of the drug to more polar chemical entities that are usually more easily eliminated [1]. Identification of these new chemical

entities or metabolites and clearance mechanisms are important aspects of the drug development process because the presence of active circulating metabolites can influence drug bioavailability and clearance, which in turn can influence the efficacy and toxicity of the drug. To meet the increasing demands in the drug development process, the field of drug metabolism has changed, such that pharmaceutical companies are looking at ways to increase their productivity while reducing timelines and costs.

* Corresponding author. Tel.: +1-734-622-2435; fax: +1-734-622-1459.

E-mail address: ragu.ramanathan@pfizer.com (R. Ramanathan).

When a drug is declared a lead or pre-lead candidate, relevant *in vitro* and *in vivo* experiments are carried out using a radiolabeled form of the drug to support safety studies prior to first dose to humans. In the traditional approach, bile, urine and plasma extracts and extracts from *in vitro* incubates were analyzed for radioactivity by liquid scintillation counting (LSC) directly while fecal homogenate underwent combustion, using an oxidizer prior to LSC. Samples or extracts containing radioactivity were separated and profiled using thin-layer chromatography (TLC) and the TLC scrapings were then submitted for mass spectrometric (MS) or nuclear magnetic resonance (NMR) characterization [2]. The advent of high-performance liquid chromatography (HPLC) during the 1970s changed the metabolite profiling process, 0.5–1 min fractions were collected from the HPLC elute and the radioactivity was determined followed by generating the histograms to study the fate of a drug [3]. The fractions containing radioactivity were analyzed using MS and NMR techniques.

During the 1980s, the introduction of radioactivity flow detectors and subsequent improvements made to them triggered further changes in metabolite profiling process [4]. Although heterogeneous radioactivity detectors were introduced first and had the advantage of recovery of radiolabeled metabolites following detection, these detectors suffered from lack of sensitivity and radioactivity contamination. Shortly after their introduction, homogeneous detectors prevailed due to their counting efficiency for ^{14}C and ^3H , minimal contamination problems, increase in sensitivity and improvements in background efficiency. The altered metabolite profiling process required higher concentrations of radioactivity as compared with fraction collection but allowed the metabolism scientist to observe the radioactive profile as it eluted off the LC column and significantly reducing the time necessary for profiling. These metabolite-profiling experiments were usually performed using either 4.6×250 or 4.6×150 mm columns to allow for maximum loading of the raw bile and urine samples from an *in vivo* study. Metabolites isolated by fraction collection process in conjunction with HPLC-RAM were

submitted for MS/MS and/or NMR characterization following solid phase extraction (SPE) or other forms of sample purification. The MS methods used in 1970s and 1980s involved loading sufficient quantities of isolated and purified metabolites ($\sim 1 \mu\text{g}$) on to an electron impact (EI) or fast atom bombardment (FAB) probe and conducting analysis using magnetic sector or triple quadrupole type mass spectrometers [5]. During the mid 1980s, thermospray ionization technique was introduced for application in the area of metabolite characterization. The technique, however, was not successful for on-line profiling and metabolite characterization due to its limited ionization capability and the pre-existing requirement of high solvent flow to the ionization source.

The advent of liquid chromatography (LC) electrospray ionization (ESI) mass spectrometry (MS) and atmospheric pressure chemical ionization (APCI) techniques during the late 1980s made possible the advances in in-line drug or metabolite characterization eliminating the need to isolate and purify metabolites [6,7]. Both ESI-LC/MS/MS and APCI-LC/MS/MS are now routinely used for quantitation and identification of metabolites directly from biological fluids and extracts. Distinguishing major metabolites from minor or trace level metabolites, however, is not possible using the LC-ESI-MS techniques alone because of differences in ionization efficiencies of functional groups of metabolites and lack of reference standards. Thus, LC-MS/MS systems were coupled with heterogeneous in-line radioactivity flow detectors. These systems were ideal for working with HPLC flow rates of 0.1–0.3 ml/min and did not require the addition of liquid scintillation cocktail. Since MS systems were coupled with heterogeneous cell systems and narrow bore columns, metabolite identification scientists were required to scale down existing methods or develop a new HPLC method rather than using the HPLC method already developed for profiling studies. In addition, MS methods needed to be sensitive because the loading capacity on a 2.1 or 1 mm column was limited to 30–50 μl of raw matrix rather than 100–125 μl , typically used during metabolite profiling. These changes often

complicated the assignment of metabolites resulting in errors in quantifying potentially toxic metabolites.

One alternative solution to improve productivity and accuracy, while reducing timelines and costs, is through combining metabolite-profiling studies with the metabolite characterization process. This can be achieved through post column splitting of the HPLC effluent and simultaneously analyzing the sample using both a homogeneous radioactivity detector and a mass spectrometer. In this paper, we will demonstrate the use of homogeneous radioactivity detection coupled with mass spectrometry for simultaneous profiling and characterization of metabolites from three drug candidates (CI-1031, CI-1030 and CI-XXXX) from different therapeutic areas. Results from homogeneous radioactivity flow detection-LC-MS/MS (parallel mode) are compared with that of heterogeneous radioactivity detection-LC-MS/MS (serial mode).

2. Experimental

All samples were obtained from the Department of Pharmacokinetics, Dynamics and Metabolism (PDM) at Pfizer Global Research and Development (PGRD-Ann Arbor). Rat and dog urine and bile samples, 25–100 μ l aliquots, were injected directly. Ammonium acetate and ammonium formate were purchased from Sigma (St. Louis, MO), HPLC grade acetonitrile from Burdick and Jackson (Muskegon, MI) and Water was purified using a Millipore Milli-Q_{plus} water purification system (Bedford, MA).

The first compound investigated was CI-1031 (ZK 807834) (2-{2-(5-Amidino-2-hydroxyphenoxy)-3,5-difluoro-*N*-methyl-6-[3-(1-methyl-4,5-dihydro-1H-[2-¹⁴C]imidazol-2-yl)-phenoxy]-4-pyridylamino}-acetic acid) (Fig. 3), which is a synthetic anticoagulant agent that is being developed as a direct inhibitor of the clotting cascade factor, Factor X_a. This factor catalyzes the conversion of prothrombin to thrombin, which in turn catalyzes the conversion of fibrinogen to fibrin to stabilize clotting. As reported previously [8], eight intact and four bile duct-cannu-

lated male Wistar rats each received an intravenous bolus injection of [¹⁴C]CI-1031 (1 mg/kg) via the tail vein and then the routes of excretion, mass balance, and metabolic profiles were determined using urine, bile and feces collected from each animal.

The second compound investigated was CI-1030, 7-[4-(4-Chloro-phenyl)-piperazin-1-ylmethyl]-4H-benzo[1,4] oxazin-3-one (Fig. 3), a selective dopamine D4 receptor antagonist that was being considered as an antipsychotic agent for the treatment of schizophrenia. Overproduction of dopamine has been associated with schizophrenia. Preclinical studies have shown that CI-1030 has good bioavailability, brain penetration, and a potent affinity and good selectivity for the D4 dopamine receptor.

The third compound investigated was CI-XXXX, a selective endothelin A receptor antagonist in development for the treatment of pulmonary hypertension and pulmonary hypertension in congestive heart failure. The structure and the chemical name of the drug and the metabolites are not provided due to proprietary issues.

2.1. Mass spectrometers

All LC-MS and LC-MS/MS experiments were performed using either a Finnigan Quadrupole Ion Trap Mass Spectrometer (LCQ-Deca, ThermoFinnigan, San Jose, CA) coupled with a HP 1100 HPLC or a Perkin Elmer (PE) Sciex API 3000 triple quadrupole mass spectrometer (PE Sciex, Foster City, CA) coupled with a PE 200 series HPLC. All HPLC systems were equipped with UV and radioactivity detectors and analog outputs were collected using the MS data acquisition software. For all Sciex API 3000 experiments, an Apple™ Macintosh® system was used for instrument control, data acquisition and data processing. Sample Control™ software (Version 1.4, PE Sciex) was used for data acquisition and Multiview™ data analysis software (Version 1.4, PE Sciex) was used for processing the data. The mass spectrometer was operated in the positive ion mode for performing metabolite characterization studies associated with CI-

1031 and CI-1030. The ionspray needle, orifice and ring electrodes were maintained at 5000, 55 and 300 V, respectively. Nitrogen was used separately as collision, TurboIonSpray, nebulizer and curtain gas. The TurboIonSpray gas was heated to 350 °C to assist in desolvation. LC-MS spectra were acquired by scanning Q1 from m/z 100–1250 in 0.3 amu steps with 0.9 ms dwell time.

For experiments using the LCQ mass spectrometer, data acquisition, analysis and processing were achieved using Xcalibur™ software (Version 1.1, ThermoFinnigan, San Jose, CA) on a Windows NT based computer system. For CI-1031 and CI-1030, ESI conditions on the ion trap mass spectrometer were as follows, spray needle: 4.5–5 kV, capillary temperature 300–350 °C; capillary voltage: 5–6 V, tube lens offset: 35–45 V; sheath gas (N₂): 70 PSI; auxiliary gas (N₂): 3 ml/min. LC-MS scan range was 100–1250 Da. For all studies involving CI-XXXX, the negative ionization mode was used and conditions applied to the ion trap mass spectrometer were as follows: spray needle: –4.5 kV, capillary temperature 300–350 °C; capillary voltage: 5–6 V, tube lens offset: 35–45 V; sheath gas (N₂): 70 PSI; auxiliary gas (N₂): 3 ml/min.

2.2. Heterogeneous in-line radioactivity flow detector (serial mode)

The effluent from the HPLC column (usually a 2.1 × 150 mm, 5 μm) was introduced in series into a UV detector, a 50 μl solid Lithium glass flow cell of a radioactive detector (β-RAM, IN/US, Tampa, FL) and then finally into the mass spectrometer via a TurboIonSpray™ or electrospray interface (Fig. 1). Analog outputs from the UV and the radioactivity detectors were recorded in real time by the mass spectrometer data system, which provided simultaneous detection of UV and radioactivity response and MS data. The delay in response between the RAM detector and MS was 0.2–0.3 min with the β-RAM response being recorded first. The UV response was recorded with a time delay of 0.1 min, with the UV being recorded first. The typical HPLC flow rate used was 0.2–0.25 ml/min.

2.3. Homogeneous in-line radioactivity flow detector (parallel mode)

Separation was normally achieved using 4.6 × 250 mm, 5 μm column with a HPLC flow rate of 1.0 ml/min. After passing through the UV detector, the HPLC effluent was split so that 25% of the flow was introduced into the mass spectrometer via a TurboIonSpray™ or electrospray interface (Fig. 2) and 75% diverted to the radioactivity detector equipped with a 500 μl liquid flow cell. The split ratio was changed as needed by adjusting the length of the post column PEEK™ tubing. An in-line check valve was used to prevent any scintillation cocktail from entering the mass spectrometer. Ultima Flo-M™ cocktail (Packard, Meridian, CT) was used as scintillation fluid at a flow rate of 2.4 ml/min. The analog outputs from the UV and the radioactivity detectors were recorded in real time by the mass spectrometer data system, which provided simultaneous detection of UV and radioactivity response and MS data. A separate software package (Win-Flow™ version 1.5 from IN/US, Tampa, FL) controlling the β-RAM also collected the analog output from the β-RAM and the data was integrated to obtain quantitative information about the metabolites and unchanged drug. The delay in response between the radioactivity detector and MS was 0.1–0.4 min with the MS response being recorded first. The UV response, however, was recorded 0.05–0.15 min before the MS response.

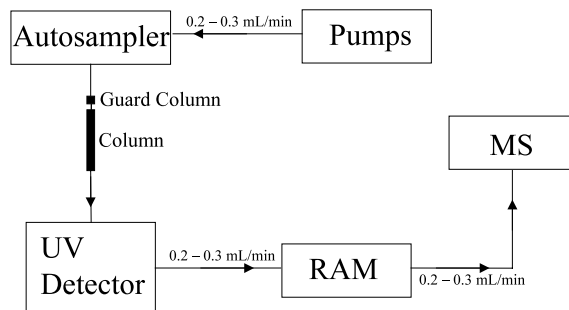

Fig. 1. Schematic diagram of a LC-MS system with a heterogeneous in-line radioactivity flow detector.

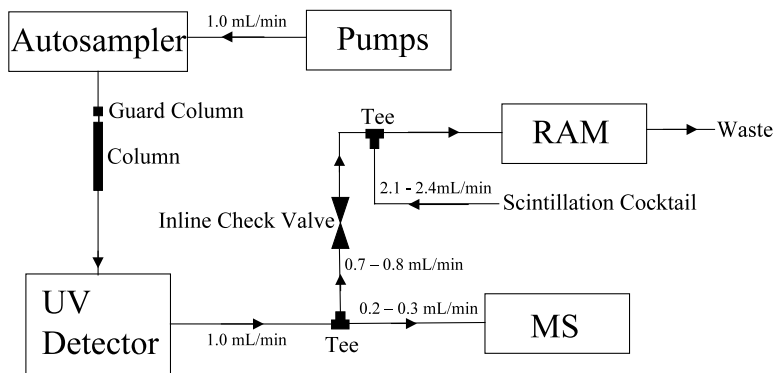

Fig. 2. Schematic diagram of a LC-MS system with a homogeneous in-line radioactivity flow detector.

2.4. HPLC and column recovery

HPLC was performed using either PE series 200 micropumps and autosampler (Perkin Elmer, Norwalk, CT) or HP 1100 binary pump and autosampler (Agilent Technologies, Wilmington, DE).

For CI-1031 samples, gradient elution of the drug and metabolites was achieved using either a 250×4.6 or 150×2.1 mm Zorbax SB C-18 column and a Zorbax SB C-18 guard column. The mobile phase, maintained at either 1.0 or 0.25 ml/min, consisted of 0.1% formic acid (Solvent A) and acetonitrile (Solvent B) [8]. For CI-1030, the mobile phase consisted of 20 mM ammonium acetate in water adjusted to pH 4.0 with acetic acid (Solvent A) and acetonitrile (Solvent B), was maintained at a constant flow rate (1.0 or 0.25 ml/min). Gradient elution of the drug and the metabolites was achieved using either a Luna C18 [9], 4.6×250 or 2.0×150 mm, 5 μ m particle size (Phenomenex, Torrance, CA) column and a MetaGuard Polaris C18, 5 μ m (MetaChem, Torrance, CA) guard column. The HPLC gradient started at 95/5 A/B and held constant for 5 min then changed linearly to 90% B over 60–70 min then the system was allowed to re-equilibrate for 5 min. Total run time was 75 min. For CI-XXXX, gradient elution of unchanged drug and the metabolites was achieved on either a 4.6×150 mm, 5 μ m (flow rate: 1.0 ml/min) or 2.1×150 mm, 5 μ m (flow rate 0.25 ml/min) Zorbax RX-C8 column. Gradient elution began at 90% of 20-mM

ammonium acetate (pH 4.0 with glacial acetic acid) and 10% acetonitrile. The mobile phase was held constant over 5 min then changed linearly to 90% acetonitrile over 55 min and allowed to re-equilibrate for 15 min. Total run time was 75 min.

Column recovery experiments were performed by injecting samples with known amounts of radioactivity onto the HPLC column and counting an aliquot of the effluent from the RAM detector. Column recovery experiments with the homogeneous radioactivity detector system was straightforward and involved collecting the scintillation cocktail/HPLC effluent mixture diverted to waste (Figs. 2 and 3) and counting an aliquot by LSC. Finally, column recovery was determined after taking the split ratio into account. Column recovery experiments with a heterogeneous radioactivity flow detector system involved a separate injection and collecting the effluent from the radioactivity detector (Fig. 1) and counting an aliquot by LSC after mixing with scintillation cocktail. Column recovery was more than 90% for each experiment described in this paper. Column recovery was taken into account when determining the percentage of analyzed radioactivity associated with unchanged drug and metabolites.

3. Results and discussion

We have selected profiling and metabolite characterization studies of 3 drug candidates from

different therapeutic areas to show direct comparison of heterogeneous radioactivity flow detector-LC-MS/MS system with that of homogeneous radioactivity flow detector-LC-MS/MS system (serial vs. parallel).

3.1. CI-1031

Mass balance studies showed that approximately 99% of the administered radioactivity was excreted in the feces and urine within 48 h post-dose. In intact rats, 61 and 39% of the dose was excreted in feces and urine, respectively, while in bile duct-cannulated rats 59, 37 and 3% of the administered dose was accounted for in bile, urine and feces, respectively. The availability of the entire sample for analysis by radioactivity flow detection and MS combined with the ability to use a narrow bore column and thus operate the HPLC at ESI suitable flow rates of 0.2–0.3 ml/min favored the use of heterogeneous radioactivity flow detector-LC-MS/MS systems. As shown in panel A of Fig. 4, the radioactivity response for the metabolite and unchanged drug was dispersed over 5 and 25 min, respectively. Unlike most drug molecules, which give predominantly singly charged molecular ions for unchanged drug and metabolites, CI-1031 and metabolites formed abundant doubly charged precursor ions (Fig. 5). Metabolite characterization was hampered due to: [1] formation of singly- and abundant doubly-charged molecular ions and [2] MS ion signal dispersion due to sample adhering to the 50 μ l cell

of the heterogeneous radioactivity flow detector. Metabolite profiling was nearly impossible due to peak shapes and the possibility of other radioactive peaks being under both M_1 and unchanged CI-1031 (Fig. 4, Panel A). Thus, using the radiochromatogram shown in Panel A (Fig. 4), it was not possible to estimate how much of the administered dose in bile was associated with the unchanged drug and individual metabolites. Other HPLC gradients, mobile phase compositions and column types were evaluated to ensure that peak shapes being observed and sample dispersion were due to CI-1031 and its metabolites adhering to the cell of the radioactivity flow detector.

To further prove that the observed peak dispersion was due to adherence of the compound to the solid-cell of the radioactivity detector, the narrow bore column was replaced with a 4.6×250 mm analytical column and the HPLC flow rate was changed to 1.0 ml/min. The HPLC effluent was split to deliver 25% of the effluent to the mass spectrometer and the rest to the waste. As shown in panel B of Fig. 4, these changes improved peak shapes and decreased the peak widths of M_1 and the unchanged CI-1031 to 2 and 7 min, respectively. After these modifications to the set-up, the major radioactive peak detected in bile and urine was characterized as unchanged CI-1031, while the second most prominent radioactive component was characterized as a glucuronide conjugate of CI-1031. Metabolite profiling and unambiguous characterization, however, were not possible because of peak dispersion.

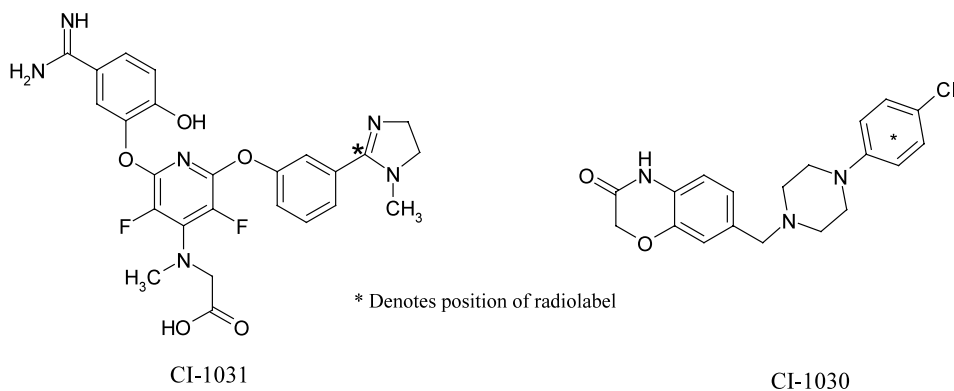

Fig. 3. Structures of the drug molecules investigated.

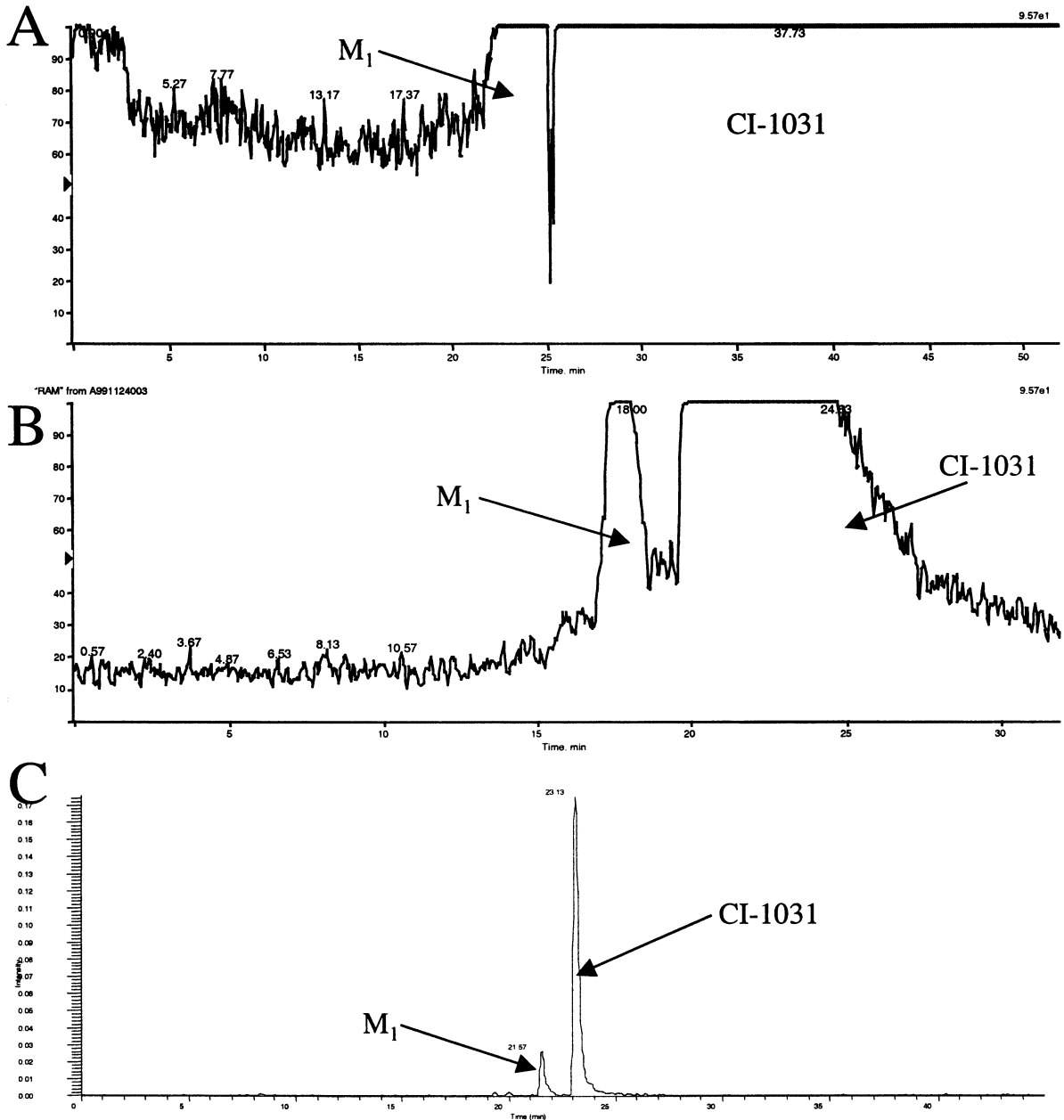

Fig. 4. HPLC radiochromatograms of 0–4 h urine following a single 1 mg/kg intravenous bolus dose of [^{14}C]CI-1031 to male rats obtained using (A) heterogeneous in-line radioactivity flow detector with 0.25 ml/min HPLC flow rate, (B) heterogeneous in-line radioactivity flow detector with 1 ml/min HPLC flow rate and (C) homogeneous in-line radioactivity flow detector with 1 ml/min HPLC flow rate.

In contrast to serial set-up, where the entire sample is available for analysis by the radioactivity detector and all (when using narrow bore

column) or portion (when using analytical column with a split before the mass spectrometer ion source) of the sample to the mass spectrometer,

parallel mode of operation requires the arrangement of a defined solvent split to each instrument and mixing of scintillation cocktail. Although this requires some minimal set-up work, the benefits certainly outweigh the initial difficulties. One limitation of the parallel set-up is unavailability of the entire sample for analysis by either the mass spectrometer or the radioactivity detector. However, the ability to load 2–3 times the volume of raw bile or urine on an analytical column compared with a narrow bore column and the added sensitivity of a homogeneous radioactivity flow detector compensates for the losses associated with sample splitting. Other benefits, as shown in panel C of Fig. 4, include improved peak shape and straightforward assignment of radiolabeled peaks. Peak widths of M_1 and unchanged CI-1031 were improved to 0.6 and 0.9 min, respectively. Absence of peak dispersion clearly showed that the major radioactivity component in rat urine was associated with unchanged CI-1031 and M_1 (CI-1031-glucuronide) was a minor component. LC-ESI-MS spectra of CI-1031 and related components showed abundant doubly charged molecular ions. Singly and doubly charged pro-

tonated molecular ions for CI-1031 were detected at m/z 529 and 265, respectively (Fig. 5). Similarly, singly and doubly charged protonated molecular ions for a glucuronide conjugate of CI-1031 were detected at m/z 705 and 353, respectively (Fig. 5). Although abundant doubly charged molecular ions were detected, singly charged molecular ion provided structurally informative fragment ions [8]. LCQ MS/MS spectra showed structurally important fragment ions of m/z 688, 571 and 512 corresponding respectively to $[(\text{CI-1031-glucuronide})\text{H-NH}_3]^+$, $[(\text{CI-1031-glucuronide})\text{H-5-amidino-2-hydroxyphenyl}]^+$ and $[(\text{CI-1031})\text{H-NH}_3]^+$. Although these fragment ions are not important for characterizing the glucuronide conjugate of CI-1031, had there been hydroxylation or another modification on the 5-amidino-2-hydroxyphenyl moiety, we would have been able to identify the site of modification using the MS/MS spectra of singly charged ions. We could not have achieved this with the use of the serial set up due to presence of less abundant singly charged molecular ions and dispersion of the ion signal available for MS/MS experiments.

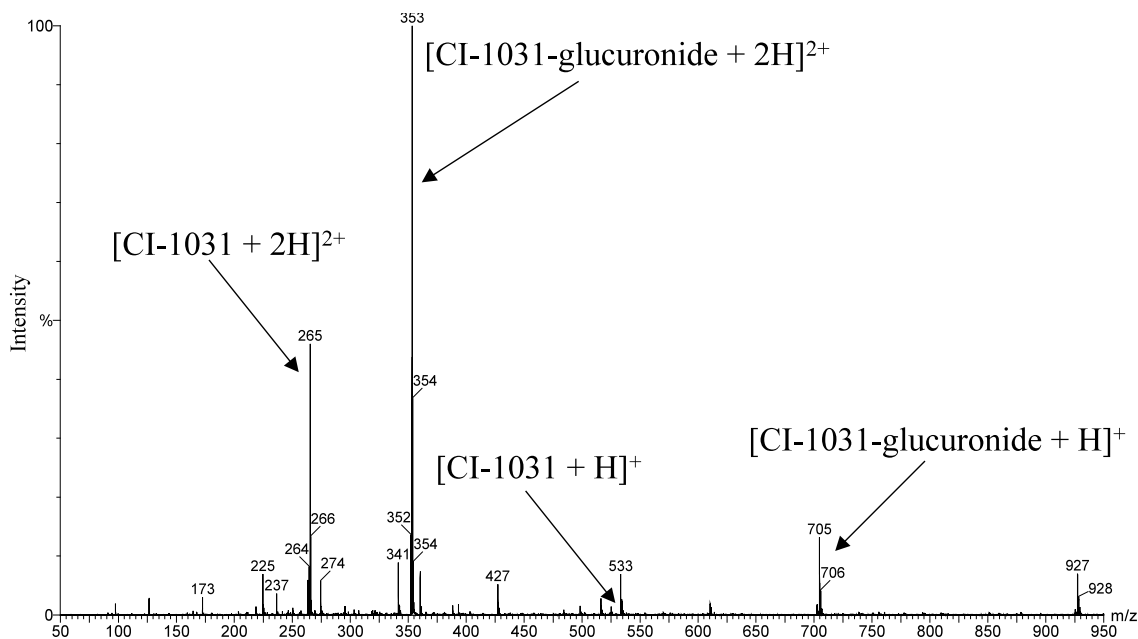

Fig. 5. LC-MS Spectrum of 0–4 h urine following a single 1 mg/kg intravenous bolus dose of $[^{14}\text{C}]$ CI-1031 to male rats.

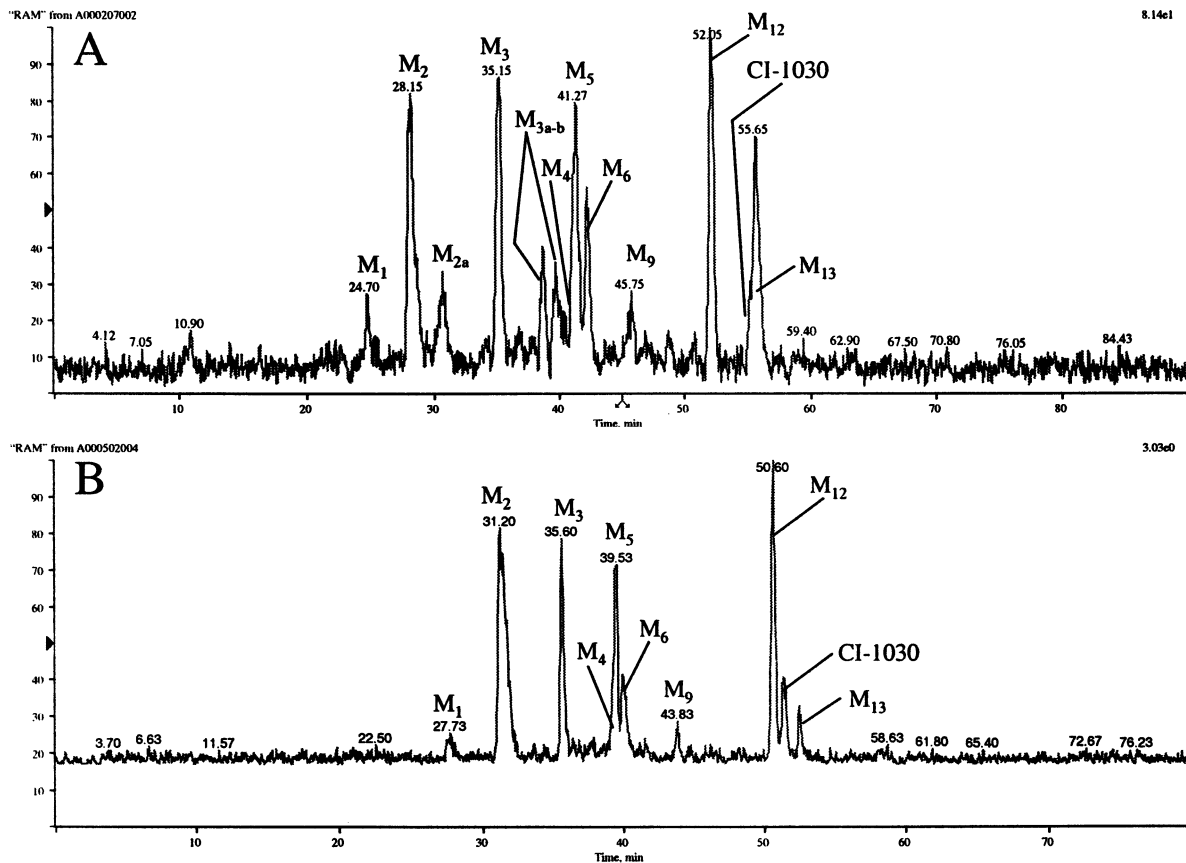

Fig. 6. HPLC radiochromatograms of 0–8 h urine following a single 5 mg/kg oral administration of [^{14}C]CI-1030 to male dogs obtained using (A) heterogeneous in-line radioactivity flow detector with 0.25 ml/min HPLC flow rate and (B) homogeneous in-line radioactivity flow detector with 1 ml/min HPLC flow rate.

3.2. CI-1030

As previously reported [9], mass balance and metabolite characterization studies in intact dogs show that, following a 5 mg/kg oral dose (73.5 μCi), CI-1030 is extensively metabolized and excreted primarily in feces. The radioactivity profile of dog urine concentrate obtained using a heterogeneous radioactivity flow detector in series was quite complex, with several radioactive species present (Fig. 6 Panel A). This chromatogram, however, was inconsistent with the metabolic profiling work conducted using the same sample, wherein CI-1030 and M_{13} were resolved. Here, it would appear that CI-1030 is a major component in urine when, as shown in Fig. 6 (Panel B), it is

actually a minor component when analyzed using the parallel LC-MS approach and a homogeneous cell. Since profiling and metabolite characterization was being performed simultaneously, we were able to confirm using the MS that M_{2a} , M_{3a} and M_{3b} are not drug-derived components and possibly originated through contamination of the heterogeneous cell or associated with some form of noise. Furthermore, a signal-to-noise ratio of less than 3:1 for M_{2a} , M_{3a} and M_{3b} suggests that these peaks are associated with noise.

While only minor amounts of radiolabeled CI-1030 were observed in urine, metabolite characterization of concentrated samples by LC-MS/MS showed the major urinary components to be hydroxylated-4-chloroaniline sulfate (M_2), a glu-

curonide conjugate of an open ring carboxylic acid metabolite of CI-1030 (M_3), two glucuronide conjugates of monohydroxy-CI-1030 (M_4 and M_5), ring open CI-1030-sulfate (M_{12}) and CI-1030-N-oxide (M_{13}). Several other minor components involving modification of piperazin and/or benzoxazin-3-one moieties were also characterized in urine.

Structural predictions were based on LC-MS/MS fragmentation behavior of metabolites compared with unchanged CI-1030. Two examples will be discussed. Under the described LC conditions, the radioactivity response for [^{14}C]CI-1030 was detected at 51.2 min (Fig. 7 bottom panel) and the corresponding extracted ion chromatogram (XIC) response at 51.4 min (not

shown). Protonated molecular ions of m/z 358 fragmented to yield ions of m/z 197, 162 and 134 (Fig. 7 top panel) corresponding, respectively, to [chlorophenyl-piperazine] $^+$, [methylbenzoxazin-3-one] $^+$ and [methylbenzoxazin-3-one-CO]. A scheme for possible formation of these fragment ions is shown in Fig. 7 (inset).

Metabolite M_1 , a minor radioactive component, eluted at 27.7 min and showed protonated molecular ion at m/z 565 and fragmented to yield ions of m/z 389, 373, 371, 213 and 197 (Fig. 8). Fragment ions of m/z 213 suggest that modification occurs on the chlorophenylpiperazine moiety by addition of an oxygen atom. Loss of one of the two glucuronides from the precursor ions gave rise to ions of m/z 389 and loss of the second

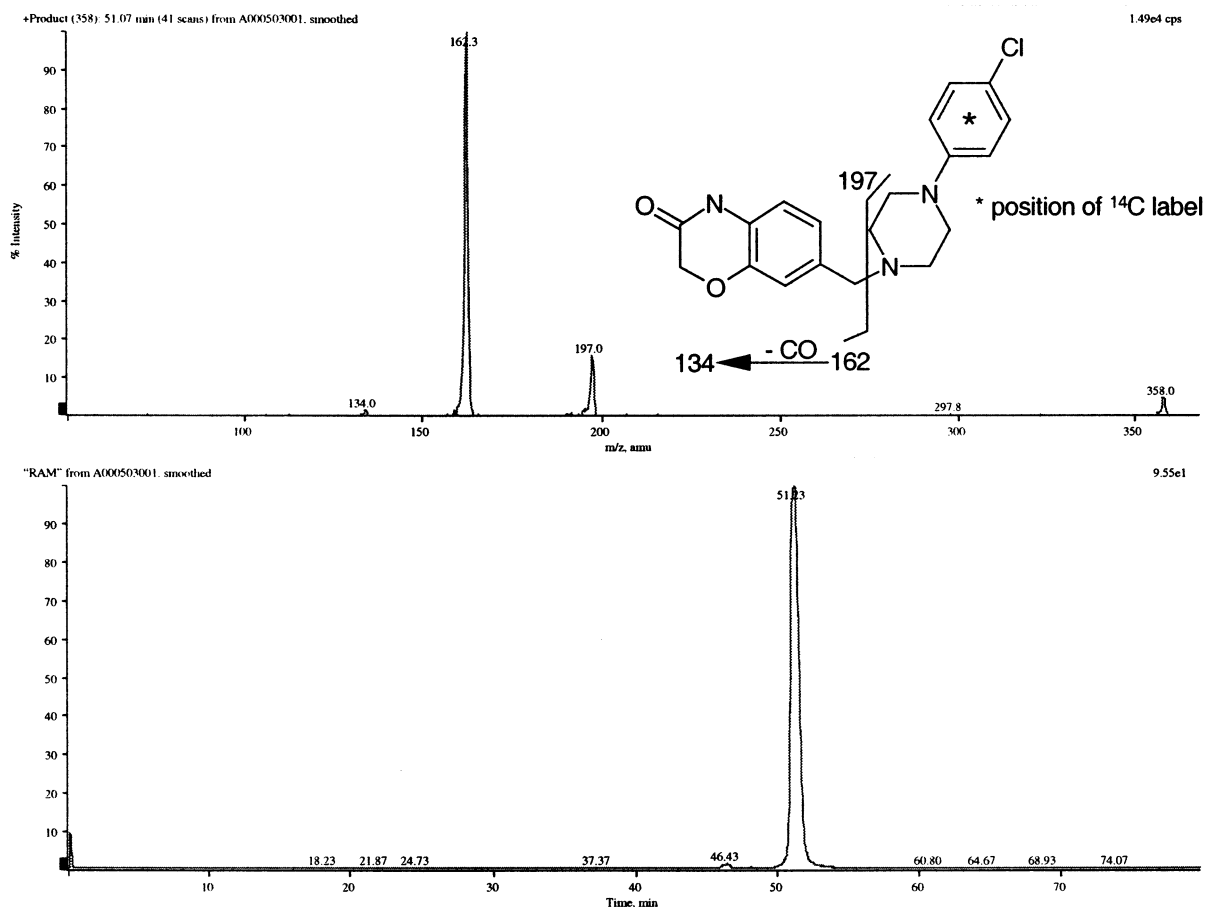

Fig. 7. Product ion spectrum for protonated molecular ion of m/z 358 from CI-1030 standard and the corresponding radiochromatogram.

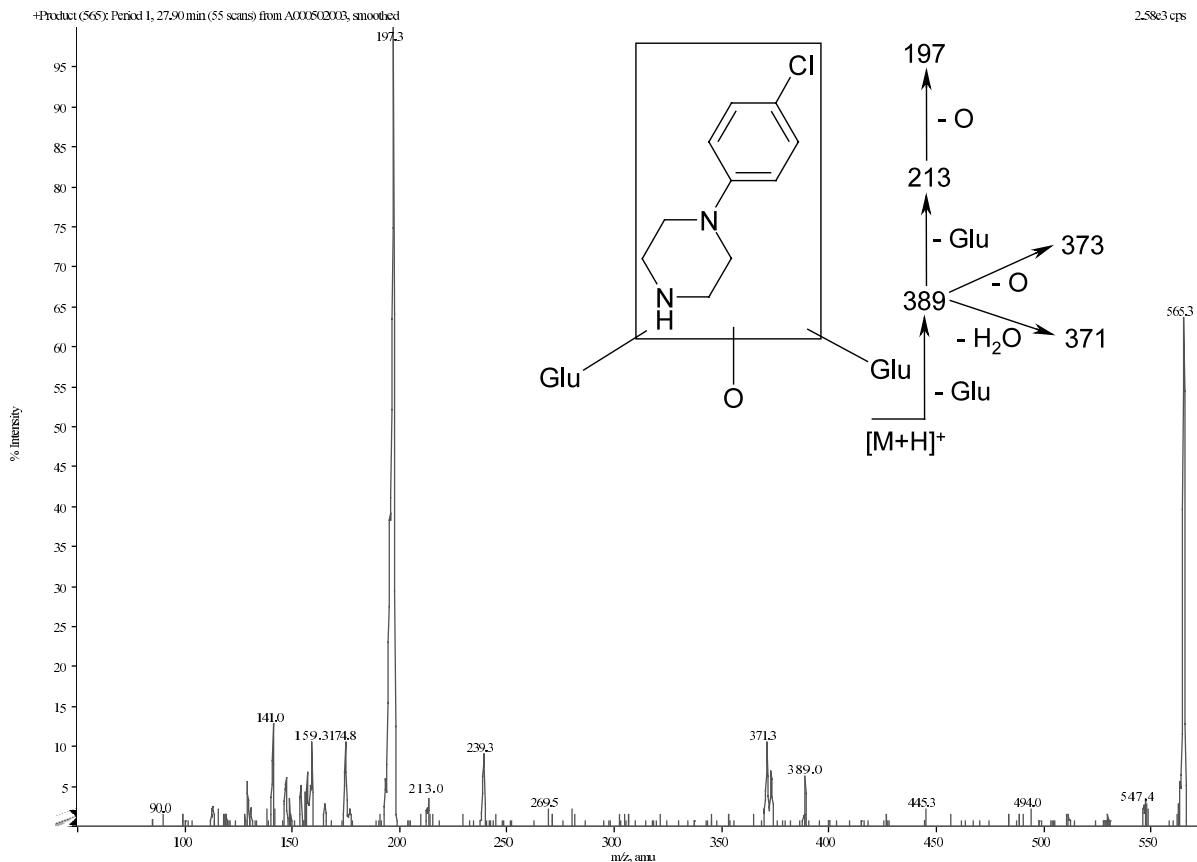

Fig. 8. Product ion spectrum for protonated molecular ions of m/z 565 from Mono-oxy-4-chlorophenyl piperazine-diglucuronide (M_1).

glucuronide results in the formation of fragment ions of m/z 213. Based on this fragmentation information, M_1 was tentatively assigned as a diglucuronide conjugate of monoxy-4-chlorophenyl piperazine metabolite. Unambiguous identification, however, requires NMR confirmation of this metabolite. Metabolite M_3 , a prominent radioactive component, eluted at 35.7 min and the precursor ions of m/z 566 fragmented to give ions of m/z 522, 390, 370, 346, 326, 197, 194, 150 and 122 (Fig. 9). Product ions of m/z 197 suggested that the chlorophenyl piperazine moiety is not modified. The presence of fragment ions corresponding to loss of a molecule of CO_2 from the precursor ions suggests the possible presence of a carboxylic acid moiety. Loss of 176 amu from the precursor ion to form ions of m/z 390

indicates the presence of glucuronic acid conjugate. Similarly, loss of a glucuronide from fragment ions of m/z 370 and 326 to give ions of m/z 194 and 150, respectively, suggests that glucuronidation is not taking place on the chlorophenylpiperazine moiety. The structure of this metabolite is consistent with a ring open carboxylic acid-CI-1030-glucuronide.

3.3. CI-XXXX

Following a single 5 mg/kg oral dose to male bile duct-cannulated Wistar rats, [^{14}C]CI-XXXX is metabolized and excreted primarily in the bile. The major biliary component was unchanged [^{14}C]CI-XXXX representing 28.0% of the dose in 0–8 h samples. Several minor metabolites were

also detected in both bile and feces. Although both serial and parallel approaches gave comparable metabolite profiling results (Fig. 10), M_5 was completely missed in the serial approach. Later, LC-MS/MS studies yielded evidence that M_5 is associated with a potentially toxic metabolite. This example clearly shows the advantage of simultaneous metabolite profiling and characterization using a homogeneous radioactivity flow detector-LC-MS/MS system. Furthermore, this example shows the absolute need for performing metabolite-profiling studies in-line with a mass spectrometer to increase the productivity while reducing timelines and costs. Had there been no mass spectrometer in-line, we could not have found that M_5 is a possible toxic metabolite and addressed all related safety issues in a timely

manner. Performing initial metabolite profiling with HPLC-RAM and submitting selected samples for metabolite identification may also have resulted in possibly missing this potentially toxic metabolite and increasing the timelines and costs.

4. Conclusions

The present study demonstrates that simultaneous metabolite profiling and metabolite characterization can be achieved by coupling a mass spectrometer with a radioactivity flow detector in either a parallel or serial approach. In a serial approach the entire sample is available for analysis by both a heterogeneous radioactivity flow detector and a mass spectrometer, however, due

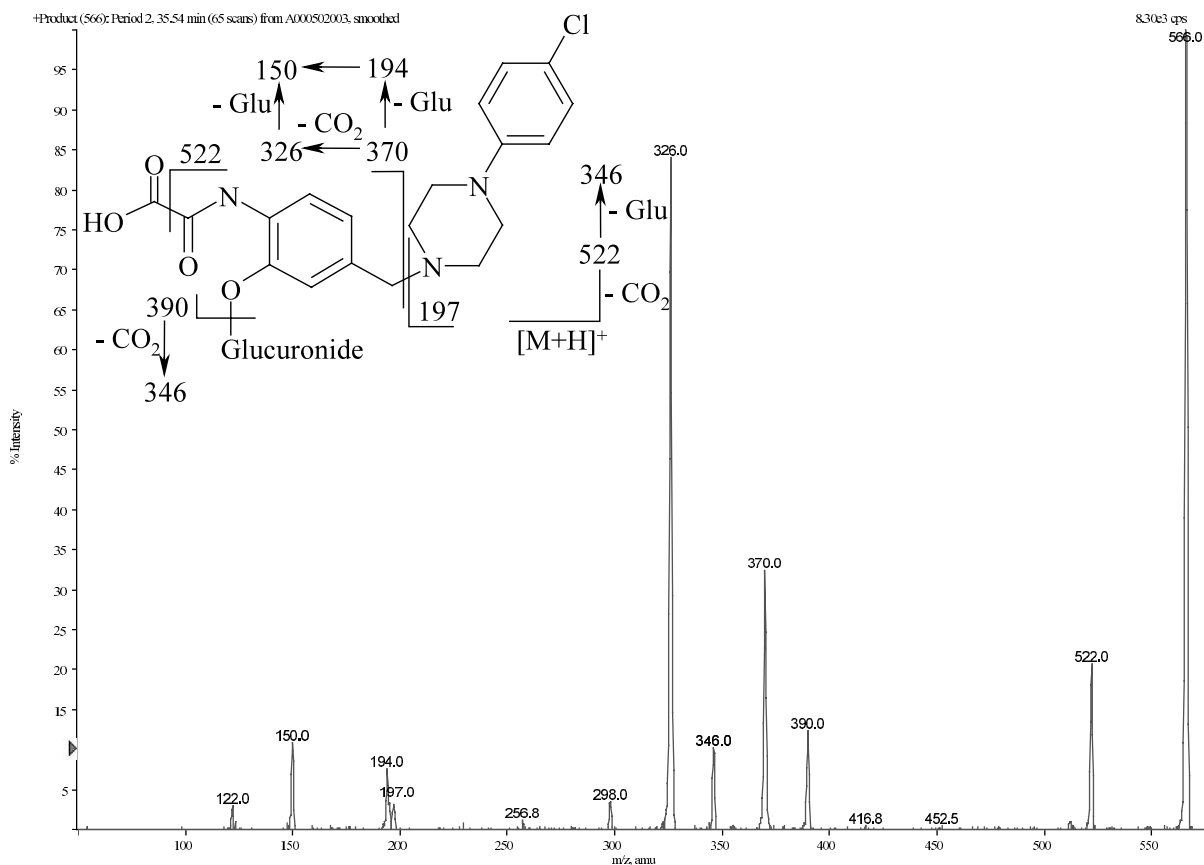

Fig. 9. Product ion spectrum for protonated molecular ions of m/z 566 from ring open carboxylic acid CI-1030-glucuronide (M_3) and the corresponding radiochromatogram.

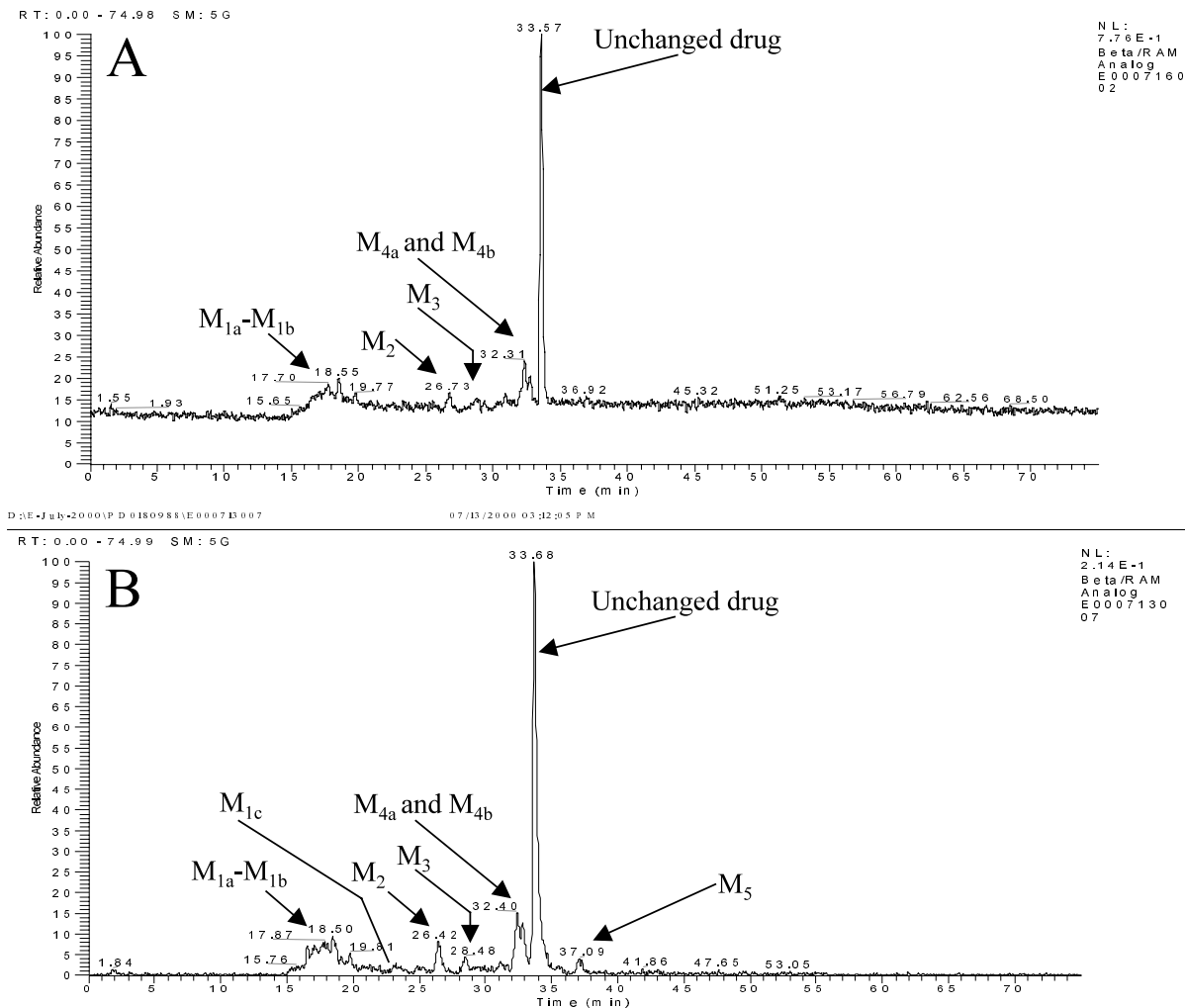

Fig. 10. HPLC radiochromatograms of 0–8 h bile following a single 5 mg/kg oral administration of [¹⁴C]CI-XXXX to male bile duct-cannulated Wistar rats obtained using (A) heterogeneous in-line radioactivity flow detector with 0.25 ml/min HPLC flow rate and (B) homogeneous in-line radioactivity flow detector with 1 ml/min HPLC flow rate.

to lack of counting efficiency for ¹⁴C and ³H and contamination problems, this approach clearly diminishes productivity. Detailed experimental results presented here clearly establish the advantage of using a homogenous in-line radioactivity flow detector in combination with LC-MS and LC-MS/MS for metabolite profiling and metabolite characterization. For the pharmaceutical industry, combining metabolite profiling and characterization methodology will significantly increase productivity while reducing timelines and costs.

Acknowledgements

The authors would like to thank Dr William Pool, Dr Jasminder Sahi and Kimberly Lapham for providing helpful suggestions.

References

- [1] T.F. Woolf, Handbook of Drug Metabolism, Marcel-Dekker, New York, 1999.

- [2] B.K. Tang, W Kalow, A.A. Grey, *Drug Metab. Disposition* 7 (5) (1979) 315–318.
- [3] R. Horgan, M.R. Kramers, *J. Chromatogr.* 173 (1979) 263–266.
- [4] V. Vlasakova, A. Brezinova, J. Holik, *J. Pharm. Biomed. Anal.* 17 (1998) 39–44.
- [5] T.F. Woolf, J.D. Adams, *Xenobiotica* 17 (1987) 839–845.
- [6] G.K. Poon, J. Wade, J. Bloomer, S.E. Clarke, J. Maltas, *Rapid Commun. Mass Spectrom.* 10 (1996) 1165–1169.
- [7] R. Singh, S.Y. Chang, L.C.E. Taylor, *Rapid Commun. Mass Spectrom.* 10 (1996) 1019–1022.
- [8] R. Ramanathan, R. Talaat, J. Sahi, *Proceedings of the 48th ASMS Conference on Mass Spectrometry and Allied Topics*, Long Beach, CA, 2000, pp. 129–130.
- [9] L. Egnash, K. Lapham, R. Talaat, R. Ramanathan, *Proceedings of the 48th ASMS Conference on Mass Spectrometry and Allied Topics*; Long Beach, CA, 2000, pp. 1641–1642.